

MINGTAI
INTELLIGENT

YOHOMA



COMPANY INTRODUCTION 公司介绍



专注于多轴数控加工中心、机器人及机器人系统的研发、制造、销售及技术服务

深圳市铭泰智能科技有限公司（原深圳市铭泰传动元件有限公司）是一家为制造加工行业提供整体解决方案的“国家级高新技术企业”，专注于多轴数控加工中心、机器人及机器人系统的研发、制造、销售及技术服务，致力于以高品质走向高端市场打造“世界级中国品牌”，同时也是日本哈默纳科（Harmonic Drive）和纳博特斯克（Nabtesco）KSS丝杠在中国区域销售一级代理最佳合作伙伴。自2009年成立以来，始终坚持以“紧贴市场、持续改进、技术创新、科学管理、回报社会”的核心价值理念，努力打造业内标杆企业。

Shenzhen Mingtai Intelligent Technology Co., Ltd. (formerly Shenzhen Mingtai Transmission Components Co., Ltd.) is a "national high-tech enterprise" that provides overall solutions for the manufacturing and processing industries. Focus on the research and development, manufacturing, sales and technical services of multi-axis CNC machining centers, robots and robotic systems, and are committed to building a "world-class Chinese brand" with high quality to the high-end market. At the same time, it is also the best partner of Japan's Harmonic Drive and Nabtesco, KSS lead screw sales in China. Since its establishment in 2009, it has always adhered to the core value concept of "close to the market, continuous improvement, technological innovation, scientific management, and return to society", and strive to build a benchmark enterprise in the industry.

YOHOMA

主要生产、销售YOHOMA五轴转台，解决工业机加工难题，降低成本，协助企业解决问题并为企业服务。关键核心齿轮部件质保三年，其它部件质保一年。24小时内处理客户售后问题（广东省内）。

It mainly produces and sells YOHOMA five-axis turntables to solve industrial machining problems, reduce costs, and assist enterprises in solving problems and serving enterprises. The key core gear parts are guaranteed for three years, and the other parts are guaranteed for one year. Deal with customer after-sales problems within 24 hours (in Guangdong Province).

哈默纳科 Harmonic Drive

Harmonic Drive 是一种特殊的谐波齿轮传动。可应用于机器人、半导体制造设备、FA设备等广泛应用。另外，在承载人类梦想的宇宙领域，Harmonic Drive 也大有用武之地。此外，在多种需求进行精密移动的机电一体化产品，如光学测量器械、医疗器械、印刷设备等产业及技术领域发挥重要作用。

Harmonic Drive is a special harmonic gear drive. It can be applied to a wide range of applications such as robots, semiconductor manufacturing equipment, and FA equipment. In addition, Harmonic Drive is also very useful in the universe that carries human dreams. In addition, it plays an important role in various industries and technical fields such as optical measuring equipment, medical equipment, and printing equipment that require precise movement of mechatronics products.

Nabtesco Precision Equipment Company

纳博特斯克是世界上最大的精密摆线针轮减速机制造商，并生产高性能减速机、中空轴减速机以及单轴伺服执行器和控制器。我们的精密设备具有高扭矩、高刚性和高过载冲击承载力的同时，兼有高精神和非常低的回程间隙。纳博特斯克致力于成为“世界领先的航空航天、陆地以及海运设备的运动控制系统和关键零件的专家”，纳博特斯克在任何需要精密控制的领域都是您高品质和优良性能的优先选择。

Harmonic Drive is a special harmonic gear drive. It can be applied to a wide range of applications such as robots, semiconductor manufacturing equipment, and FA equipment. In addition, Harmonic Drive is also very useful in the universe that carries human dreams. In addition, it plays an important role in various industries and technical fields such as optical measuring equipment, medical equipment, and printing equipment that require precise movement of mechatronics products.



日本发明

零背隙
滚动传递无磨损

JAPANESE INVENTION

Zero backlash
Rolling transfer without wear



Yohoma 订制消隙齿轮

日本制造

高精度
高效率
高刚性

MADE IN JAPAN

High Precision
High Efficiency
High Rigidity



生产、销售 YOHOMA 五轴转台解决工业机加工难题，降低成本，协助企业解决问题并为企业服务

Production and sales of YOHOMA five-axis turntable to solve industrial machining problems, reduce costs, assist enterprises in solving problems and serve enterprises

提高品质，提高合格率，解放人工！

Improve quality, increase qualification rate, and liberate labor!

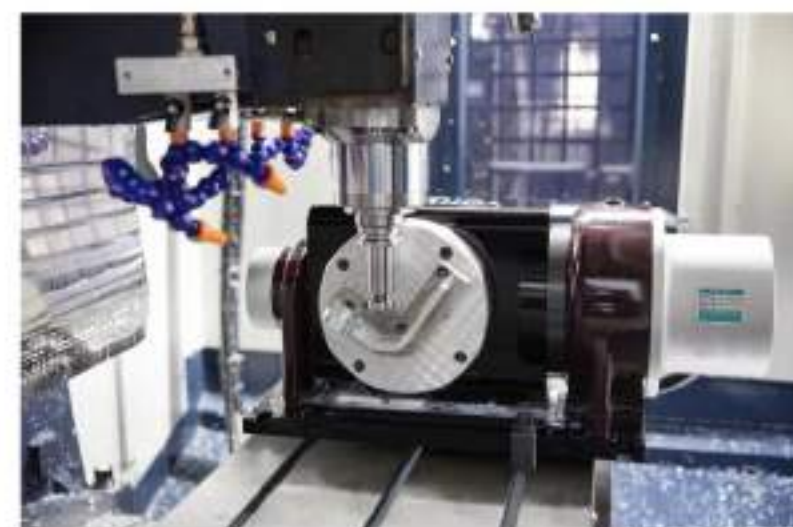

转台可以通过精准的定位，扩大原本的加工空间，不仅能提高加工的效率，而且还能减少机器的闲置。

The turntable can expand the original processing space through precise positioning, which not only improves the processing efficiency, but also reduces the idleness of the machine.



提供售前技术支持，售后维护，细节决定成败，细节成就完美。
使用三坐标仪器进行精度标定及调整，保证质量。
YHM高防护系列（定制）YOHOMA五轴IP68防护等级，
可以浸泡液体加工。

Provide pre-sales technical support, after-sales maintenance,
details determine success or failure, and details make perfect.
Use a three-coordinate instrument for precision calibration
and adjustment to ensure quality.
YHM high protection series (customized) YOHOMA five-axis
IP68 protection level, can be immersed in liquid processing.



YHM-160H五轴转台特点

- *使用NSK高精度交叉滚柱轴承
- *运用日本原装超精密消隙齿轮传动结构
- *高转矩、高精度、高刚性
- *可装配在钻攻机、650、850机床上
- *可配宝元、新代、三菱、法那科、西门子等系统
- *适用于无人机零件、医疗配件、5G通讯散热器等各类铝件加工
- *完全解决加工件需多次装夹的弊端，提升加工效率及品质

YHM-160H five-axis turntable features

- *Use NSK high-precision cross roller bearings
- *Using Japanese original ultra-precision anti-backlash gear transmission structure
- *High torque, high precision, high rigidity
- *Can be assembled on drilling and tapping machines, 650, 850 machine tools
- *Can be equipped with Baoyuan, New Generation, Mitsubishi, Fanuc, Siemens and other systems
- *Suitable for processing various aluminum parts such as drone parts, medical accessories, 5G communication radiators, etc.
- *Completely solve the disadvantages of multiple clamping of processed parts, improve processing efficiency and quality



规格/型号 Specification/Model	单位unit	YHM-160H
转台盘面直径 Diameter of turntable surface	φmm	φ160
工作台高度 Height of worktable	水平 Level	mm
中心高度 Center height	90°	mm
中心孔直径 Center hole diameter	mm	15
倾斜角度 slope	deg	±106°

轴向Axial	单位unit	旋转轴 Axis of rotation	倾斜轴 Tilt axis
最小设定单位 Minimum setting unit	deg	0.001	0.001
分度精度Indexing accuracy	sec	30°	30°
重复定位精度Repeatability	sec	3°	5°
输出承载扭矩 Output load torque	选配电机Optional motor	400w	750w/1KW
	连续/最大扭矩 Continuous/maximum torque	Nm	61/87
			153/882
总减速比 Total reduction ratio	-	1:81	1:121
容许最高转速 Allowable maximum speed	r.p.m	48/37	50/25
最大工作负载 Maximum workload	0°	kg	46
	0°~90°	kg	35

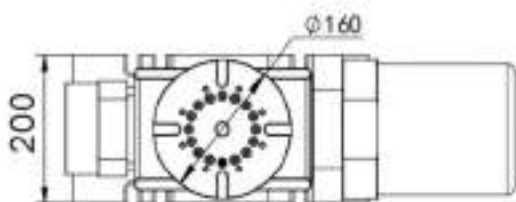
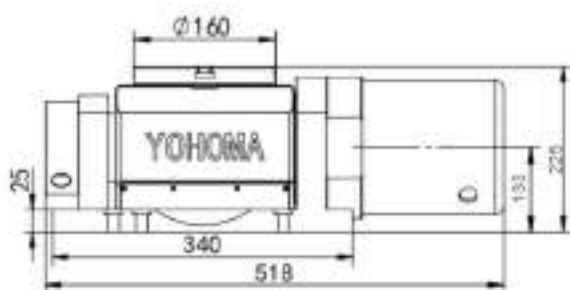

YHM-200五轴转台特点

- *使用NSK高精度交叉滚柱轴承
- *运用日本原装超精密消隙齿轮传动结构
- *高转矩、高精度、高刚性
- *可装配钻攻机Z轴加高、650、850机床上
- *可配宝元、新代、三菱、西门子等系统
- *适用于无人机零件、医疗器械零件、振动盘等各类小五金铝件加工
- *完全解决加工件需多次装夹的弊端，提升加工效率及品质

YHM-200 five-axis turntable features

- *Use NSK high-precision cross roller bearings
- *Using Japanese original ultra-precision anti-backlash gear transmission structure
- *High torque, high precision, high rigidity
- *Can be equipped with drilling and tapping machine Z axis heightening, 650, 850 machine tools
- *Can be equipped with Baoyuan, New Generation, Mitsubishi, Siemens and other systems
- *Suitable for the processing of various small hardware aluminum parts such as drone parts, medical equipment parts, vibrating plates, etc.
- *Completely solve the disadvantages of multiple clamping of processed parts, improve processing efficiency and quality



规格/型号 Specification/Model	单位unit	YHM-200
转台盘面直径 Diameter of turntable surface	φmm	φ200
工作台高度 Height of worktable	水平 Level	mm
中心高度 Center height	90°	mm
中心孔直径 Center hole diameter	mm	20
倾斜角度 slope	deg	±120°

轴向Axial	单位unit	旋转轴 Axis of rotation	倾斜轴 Tilt axis
最小设定单位 Minimum setting unit	deg	0.001	0.001
分度精度Indexing accuracy	sec	23°	23°
重复定位精度Repeatability	sec	5°	5°
输出承载扭矩 Output load torque	选配电机Optional motor	400w	750w
	连续/最大扭矩 Continuous/maximum torque	Nm	153/882
			377/1866
总减速比 Total reduction ratio	-	1:121	1:121
容许最高转速 Allowable maximum speed	r.p.m	25	25
最大工作负载 Maximum workload	0°	kg	80
	0°~90°	kg	40

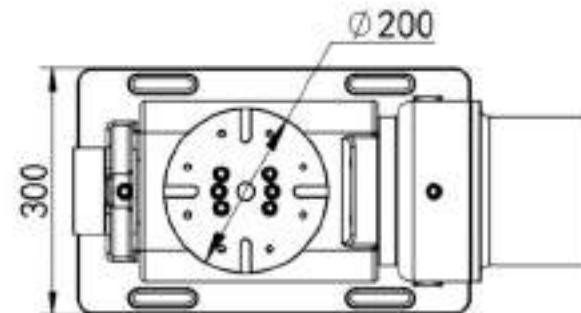
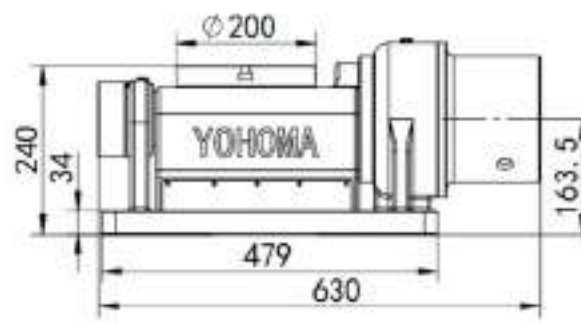



YHM-250五轴转台特点

- *使用NSK高精度交叉滚柱轴承
- *运用日本原装超精密消除齿隙传动结构
- *高转矩、高精度、高刚性
- *可装配Ø50及以上机床
- *可配宝元、新代、三菱、法那科、西门子等系统
- *适用于大振动盘精加工、自行车配件加工、钢件精加工等
- *完全解决加工件需多次装夹的弊端，提升加工效率及品质

YHM-250 five-axis turntable features

- *Use NSK high-precision cross roller bearings
- *Using Japanese original ultra-precision anti-backlash gear transmission structure
- *High torque, high precision, high rigidity
- *Can be equipped with Ø50 and above machine tools
- *Can be equipped with Baoyuan, New Generation, Mitsubishi, Fanuc, Siemens and other systems
- *Suitable for large vibrating plate finishing, bicycle parts processing, steel finishing, etc.
- *Completely solve the disadvantages of multiple clamping of processed parts, improve processing efficiency and quality

规格/型号 Specification/Model	单位/unit	YHM-250
转台盘面直径 Diameter of turntable surface	φmm	φ250
工作台高度 Height of worktable	水平 Level	mm
296.5		
中心高度 Center height	90°	mm
215		
中心孔直径 Center hole diameter	mm	20
倾斜角度 slope	deg	±120°

轴向Axial	单位/unit	旋转轴 Axis of rotation	倾斜轴 Tilt axis
最小设定单位 Minimum setting unit	deg	0.001	0.001
分度精度Indexing accuracy	sec	23"	23"
重复定位精度Repeatability	sec	5"	5"
输出承载扭矩 Output load torque	选配电机Optional motor	-	1Kw
	连续/最大扭矩 Continuous/maximum torque	Nm	882/1764
			1666/3332
总减速比 Total reduction ratio	-	1:121	1:121
容许最高转速 Allowable maximum speed	r.p.m	60/25	40/25
最大工作负载 Maximum workload	0°	kg	100
	0°~90°	kg	65

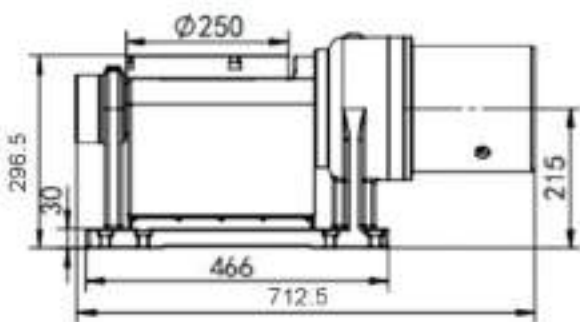
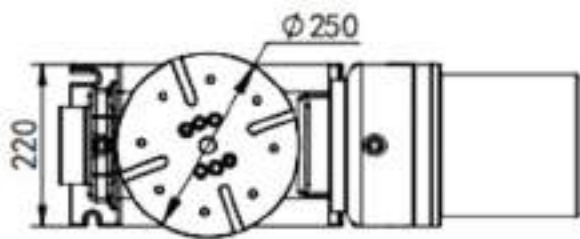

YOHOMA数控四轴转台仿真模拟结果

Simulation results of YOHOMA CNC four-axis turntable

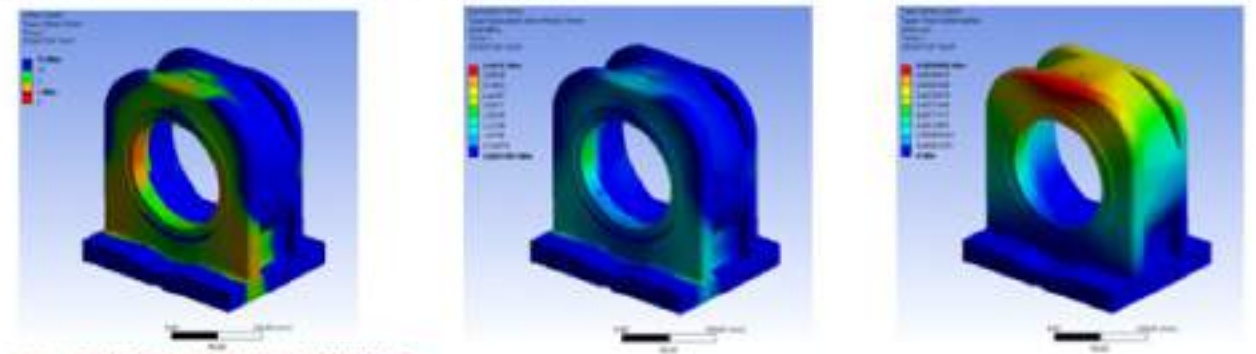

YOHOMA数控五轴转台仿真模拟结果

Simulation results of YOHOMA CNC five-axis turntable

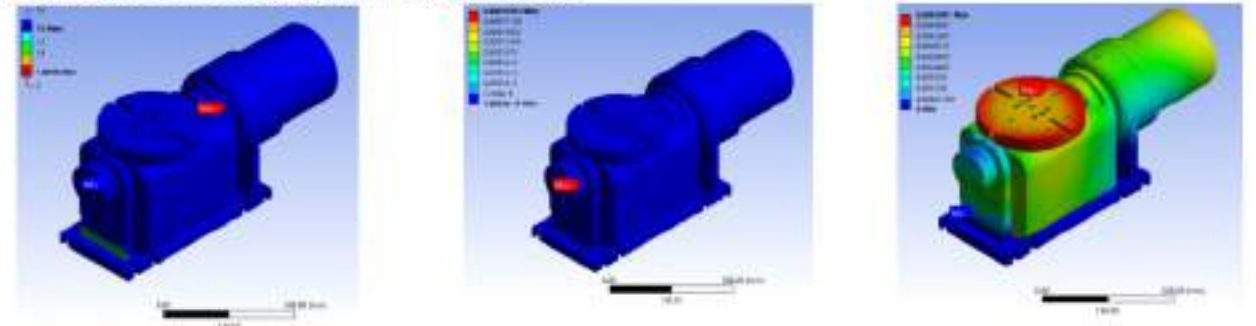

安全系数Safety factor

应力分析Stress Analysis

位移Displacement

精度的规格

Accuracy specifications

NO	检查项目	测定方法	YHM-120	YHM-160	YHM-200	YHM-250
1	旋转台盘面与底面平行度		0.01	0.01	0.015	0.02
2	旋转台盘面跳动		0.01	0.01	0.015	0.015
3	主轴中心孔径向跳动		0.01	0.01	0.015	0.015
4	0-90°角度误差		0.01	0.01	0.015	0.02
5	旋转轴分度精度	—	16sec	16sec	23sec	23sec
6	旋转轴重复定位精度	—	3sec	3sec	5sec	5sec
7	倾斜轴分度精度	累计	16sec	23sec	23sec	23sec
8	倾斜轴重复定位精度	累计	5sec	5sec	7sec	7sec

YHM-180四轴转台特点

- *采用大型高精度交叉滚柱轴承
- *采用日本原装超精密消隙齿轮传动结构
- *高转矩、高精度、高刚性
- *电机后置式配置，充分保留Y轴有效行程
- *主要应用于铝件加工

Features of YHM-180 four-axis turntable

- *Using large high-precision cross roller bearings
- *Using Japanese original ultra-precision anti-backlash gear transmission structure
- *High torque, high precision, high rigidity
- *Back configuration of the motor to fully retain the effective stroke of the Y axis
- *Mainly used in aluminum processing

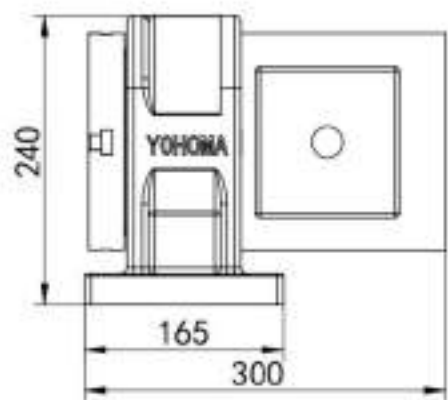
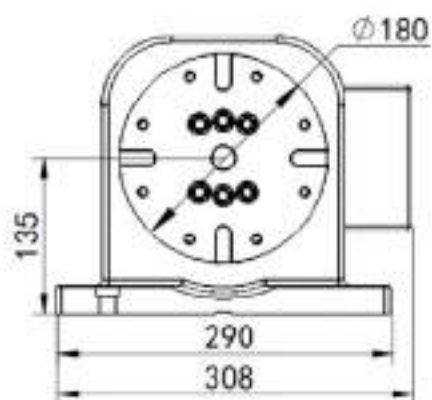

规格/型号 Specification/Model		单位unit	YHM-180
转台盘面直径 Diameter of turntable surface		φmm	φ180
工作台高度 Height of worktable	水平 Level	mm	240
中心高度 Center height	90°	mm	135
中心孔直径 Center hole diameter		mm	20
最小设定单位 Minimum setting unit		deg	0.001
分度精度Indexing accuracy		sec	23"
重复定位精度Repeatability		sec	5"
输出承载扭矩 Output load torque	选配电机Optional motor	-	1KW
	连续/最大转矩 Continuous/maximum torque	Nm	377/1666
总减速比 Total reduction ratio		-	1:121
容许最高转速 Allowable maximum speed		r.p.n	25
容许力矩 Allowable moment			800

YHM-260四轴转台特点

- *采用大型高精度交叉滚柱轴承
- *采用日本原装超精密消隙齿轮传动结构
- *高转矩、高精度、高刚性
- *电机后置式配置，充分保留Y轴有效行程
- *主要应用于铝件加工

Features of YHM-260 four-axis turntable

- *Using large high-precision cross roller bearings
- *Using Japanese original ultra-precision anti-backlash gear transmission structure
- *High torque, high precision, high rigidity
- *Back configuration of the motor to fully retain the effective stroke of the Y axis
- *Mainly used in aluminum processing

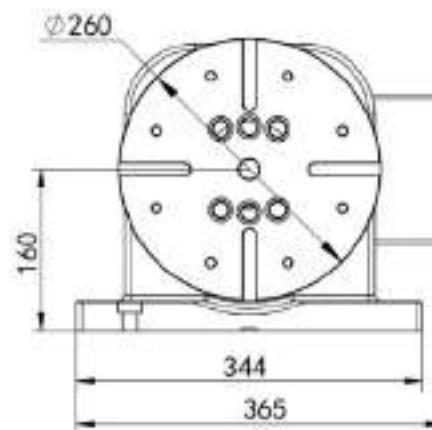
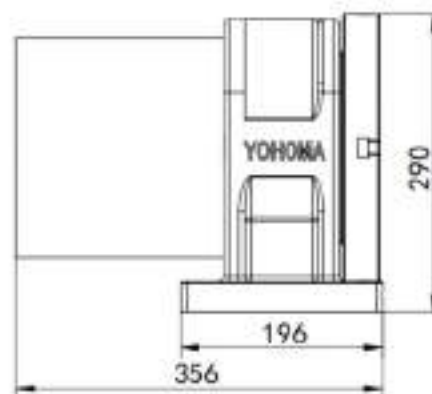

规格/型号 Specification/Model		单位unit	YHM-260
转台盘面直径 Diameter of turntable surface		φmm	φ260
工作台高度 Height of worktable	水平 Level	mm	290
中心高度 Center height	90°	mm	160
中心孔直径 Center hole diameter		mm	40
最小设定单位 Minimum setting unit		deg	0.001
分度精度Indexing accuracy		sec	23"
重复定位精度Repeatability		sec	5"
输出承载扭矩 Output load torque	选配电机Optional motor	-	1.5KW
	连续/最大转矩 Continuous/maximum torque	Nm	1666/3332
总减速比 Total reduction ratio		-	1:121
容许最高转速 Allowable maximum speed		r.p.n	25
容许力矩 Allowable moment			1500



叶轮加工 (小黄机FANUC 31i+YHM160H五轴转台)
Impeller processing (Xiaohuang machine FANUC 31i+YHM160H five-axis turntable)

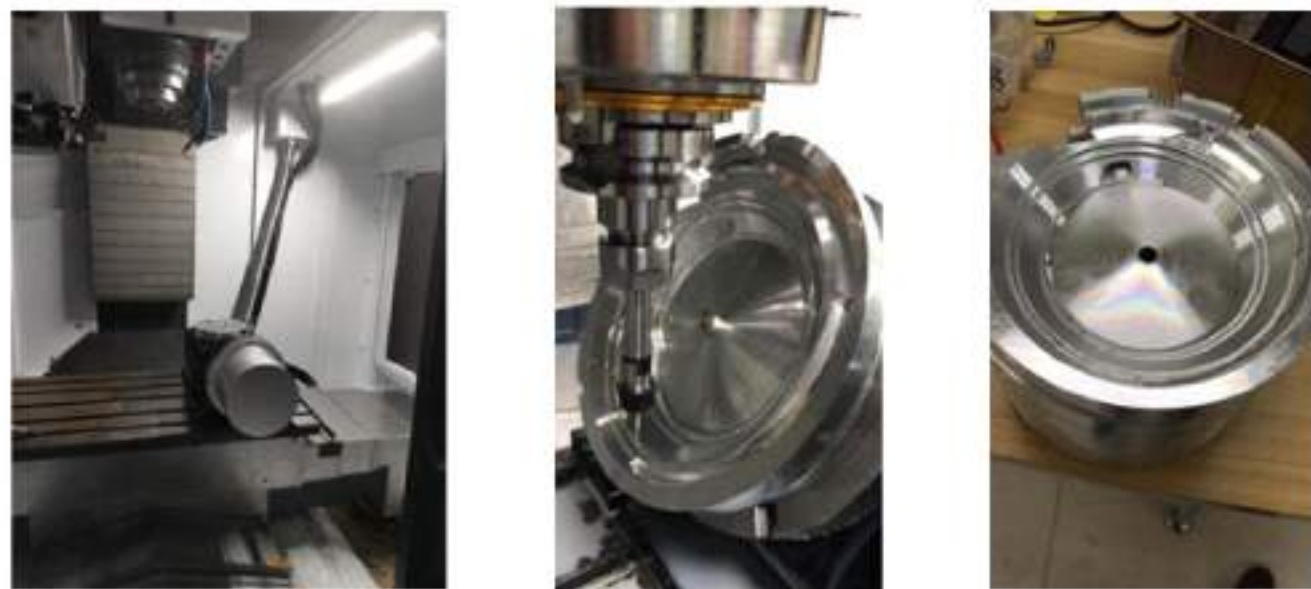

振动盘加工 (850+YHM200五轴转台)
Vibration plate processing (850+YHM200 five-axis turntable)

本公司已跟各大机床厂家合作, 可特殊定制打包五轴加工中心
The company has cooperated with major machine tool manufacturers and can customize and package five-axis machining centers.

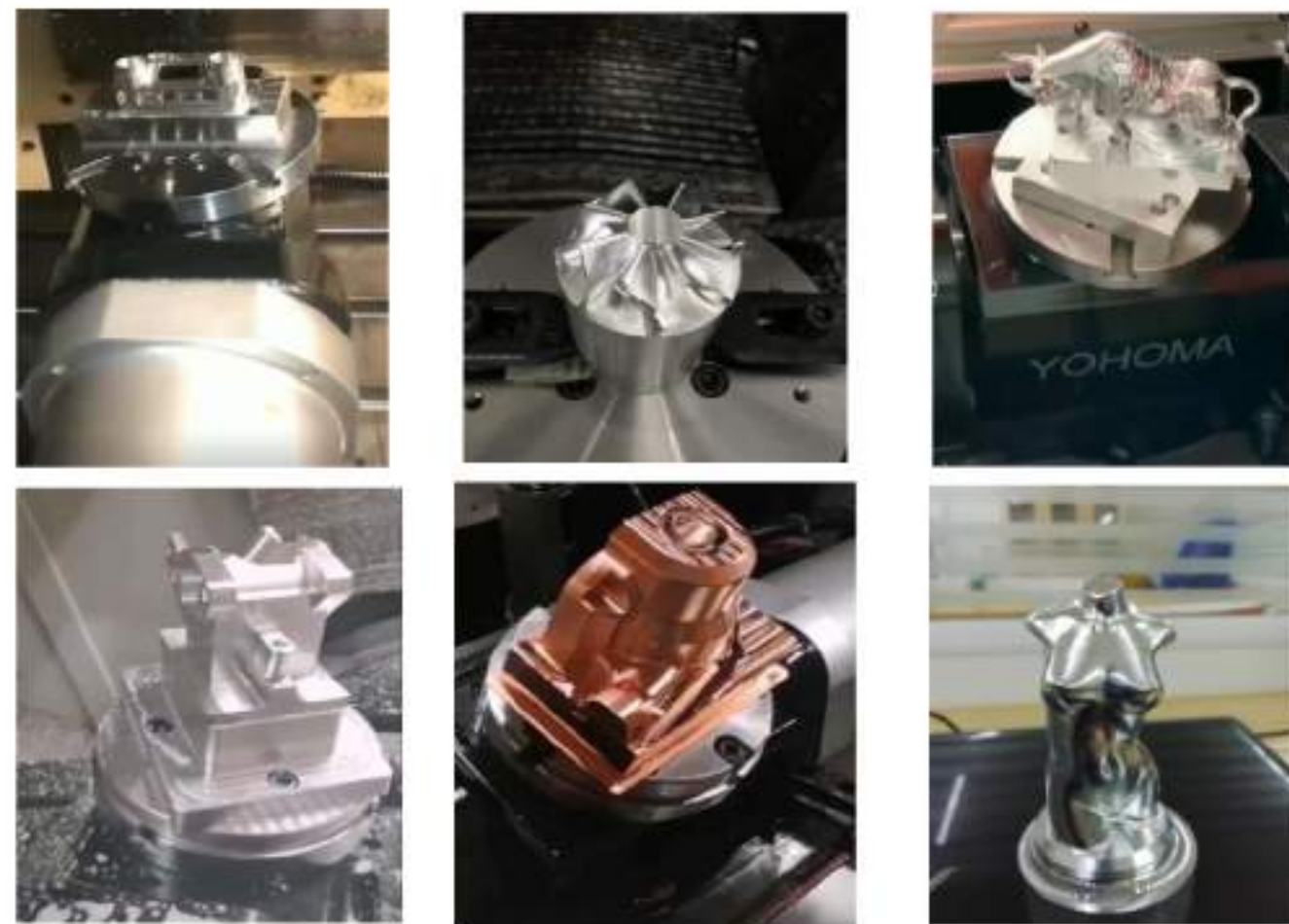

Five-axis machining center machine customization
五轴加工中心
机床定制

凸轮滚子结构组成及原理

Cam roller structure composition and principle

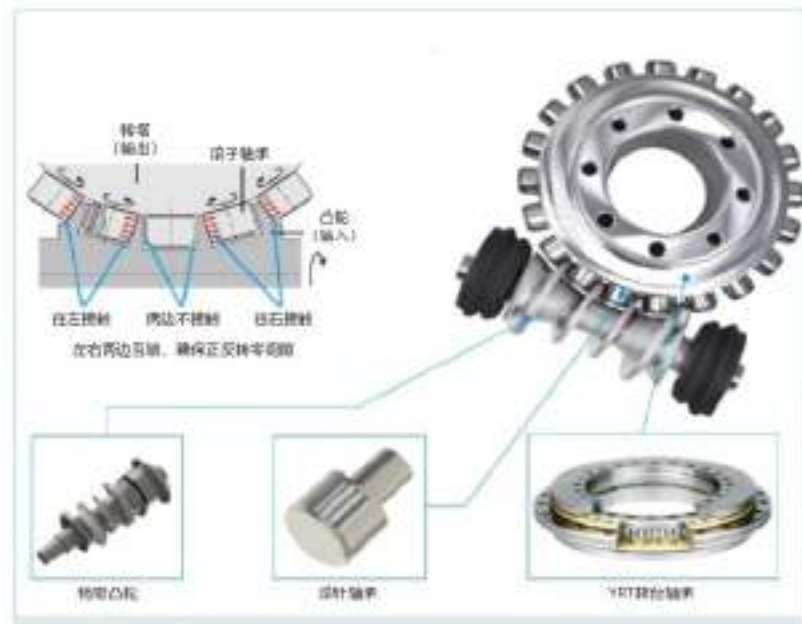

Roller Driver传动应用的是弧面分度原理，是目前最精确的运动控制方式。工作件由一个输入轴（弧面分度凸轮）及一个转塔（输出轴）组成，输入轴上的凸轮槽表面与转塔上的从动滚子元件外环表面呈线接触啮合，从而驱动转塔（即工作台）转动。从动滚子元件在旋转过程中利用内部滚柱轴承来传递扭矩。这样的工作原理保证了零间隙，优异的工作精度和工作效率，并有效地避免了内部零件损耗，提供持久的超精度工作状态。

The Roller Driver transmission uses the arc surface indexing principle, which is currently the most accurate motion control method. The work piece is composed of an input shaft (curved indexing cam) and a turret (output shaft). The cam groove surface on the input shaft meshes with the outer ring surface of the driven roller element on the turret to drive the runner (that is, the worktable) rotates. The driven roller element utilizes internal roller bearings to transmit torque during rotation. This working principle ensures zero clearance, excellent working accuracy and working efficiency, and effectively avoids the loss of internal parts, providing a lasting high-precision working state.

• 免维护，寿命长

1. 滚动传递，摩擦损耗极小；
2. 接触面常时形成油膜传动；
3. 凸轮及滚针轴承刚性高，耐磨；
4. 预压状态下使机构常时保持零间隙状态。

• 零间隙，高精度

1. 凸轮曲线和滚针轴承完美啮合；
2. 机构常时预压状态，消除反冲，
2. 即使加工时反向旋转，加工表面
3. 也能完美加工（正反转，零间隙）

• 滚动传递，效率高，定位快（分度时间短）

1. 滚动传递时，摩擦极小；
2. 接触位置更加容易形成油膜；

• 刚性高

1. 凸轮及滚针轴承材料刚性高；
2. 凸轮和滚针轴承啮合深；
3. 滚针轴承直径大，凸轮齿更厚。

缺点：

1. 时间久滚子磨损严重，整体精度不断的下降导致加工精度下降后相续修成高。
2. 长时间工作，容易发热，影响转换效率。

Disadvantages:

1. Over time, the roller wears seriously, and the overall accuracy continues to decrease, resulting in a decline in processing accuracy and a high level of maintenance in the later stage.
2. Working for a long time can easily generate heat and affect conversion efficiency.

• Maintenance-free, long life

1. Rolling transmission, very low friction loss;
2. The contact surface often forms oil film transmission;
3. Cam and needle roller bearings have high rigidity and wear resistance;
4. In the preload state, the mechanism always maintains the zero gap state.

• Zero clearance, high precision

1. The cam curve perfectly meshes with the needle bearing;
2. The mechanism is always preloaded to eliminate recoil,
2. Even if the reverse rotation during processing, the processing surface
3. It can also be processed perfectly (forward and reverse, zero gap)

• Rolling transmission, high efficiency, fast positioning (short indexing time)

1. When rolling and transferring, the friction is very small;
2. It is easier to form oil film at the contact position;

• High rigidity

1. Cam and needle bearing materials have high rigidity;
2. The engagement depth of cam and needle bearing;
3. The needle roller bearing has a large diameter and thicker cam teeth.

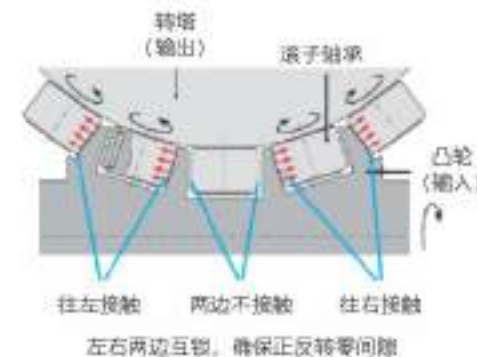

左右两边互锁，确保正反转零间隙

蜗轮蜗杆结构组成与原理

Structure composition and principle of worm gear

蜗轮蜗杆传动的两轴是相互交叉垂直的；蜗杆可以看成是在圆柱体上沿螺旋线绕有一个齿（单头）或几个齿（多头）的螺旋，蜗轮就像个斜齿轮，但它的齿包着蜗杆。在啮合时，蜗杆转一转，就带动蜗轮转过一个（单头蜗杆）或几个齿（多头蜗杆）。

The two shafts of the worm gear drive are crossed and perpendicular to each other; the worm can be regarded as a spiral with one tooth (single-head) or several teeth (multi-head) wound along a spiral on a cylinder. The worm wheel is like a helical gear, but its teeth enclose the worm. When meshing, one revolution of the worm will drive the worm wheel to turn through one (single-head worm) or several teeth (multi-head worm).

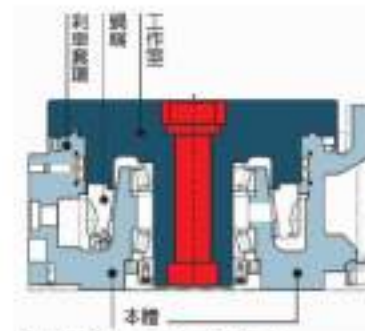

油压全覆周环抱刹車

蜗轮蜗杆结构存在间隙，在90度刹车瞬间出力轴会回转过微小角度，存在误差

• 滑动摩擦系数大

磨损大——精度降低，需要周期性背隙调整
发热严重——解决发热问题需要使用高成本的耐磨材料
传动效率低（75%）

• 结构存在间隙，必须加装刹车才能保证

定位精度，否则会出现“震刀”情况
存在刹车，电磁阀故障困扰一维修售后成本高

There is a gap in the worm gear structure, The output shaft will rotate a small angle, and there is an error

◆ Large sliding friction coefficient
Large wear-reduced accuracy, need periodic backlash adjustment
Severe fever-high cost is required to solve the problem of fever
Wear-resistant materials
Low transmission efficiency (75%)

◆ There is a gap in the structure, and a brake must be installed to ensure Positioning accuracy, otherwise there will be "shaking knife" situation
There are brakes and solenoid valve troubles → high maintenance after-sales costs

DD是DIRECT DRIVER的简称，包括力矩电机和直线电机。

DD is the abbreviation for direct driver, including torque motors and linear motors.

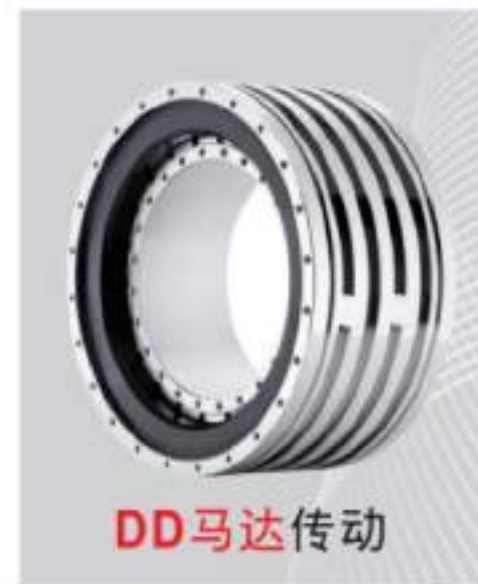

DD马达传动

后面加上电机就是称为DD直驱电机也叫直接驱动马达。由于其输出力距大，因此有些公司直接称为力矩伺服。与传统的电机不同，将该产品的大力距使其可以直接与运动装置连接，从而省去了诸如减速机、齿轮箱、皮带轮等连接机构，因此才会称为直驱电机。由于一般该型电机都配置了高分辨度的编码器，因此使该产品可以达到比普通伺服高一个等级的精度。又由于采用直接连接方式，减少了由于机械结构产生的定位误差，使得工艺精度得以保证。另外对于部分凸轮轴控制方式，一方面减少了由于机械结构摩擦而产生尺寸方面的误差，另一方面也对安装，使用时的噪音等方面降低了很多。

Adding a motor at the back is called a DD direct drive motor or a direct drive motor. Because of its large output torque, some companies directly call it a torque servo. Different from traditional motors, the product's large force distance allows it to be directly connected to the motion device, thus eliminating the need for connecting mechanisms such as reducers, gear boxes, pulleys, etc., so it is called a direct drive motor. Generally, this type of motor is equipped with a high-resolution encoder, so the product can achieve a higher level of accuracy than ordinary servo. In addition, due to the direct connection method, the positioning error caused by the mechanical structure is reduced, so that the process accuracy can be guaranteed. In addition, for some camshaft control methods, on the one hand, the dimensional error caused by the friction of the mechanical structure is reduced, and on the other hand, the noise during installation and use is greatly reduced.

1. 间隙误差被消除，DD马达没有中间传动部件，直接由DD马达驱动；
2. 机构常时预压状态，消除反冲，即使加工时反向旋转，加工表面也能完美加工（正反转，零间隙）
3. 高分辨度和高定位精度。
4. 高刚性，结构紧凑，使用率高
5. 转速快，提高加工效率。

缺点：不适合高负载，大负载运行时，时间久发热严重，容易负载报警。

Disadvantages: Not suitable for high load. When running with heavy load, it will heat up for a long time and it is easy to load alarm.

1. The gap error is eliminated, the DD motor has no intermediate transmission parts and is directly driven by the DD motor;
2. The mechanism is always preloaded to eliminate backlash, even if it rotates in the reverse direction during processing, the processed surface can be processed perfectly (forward and reverse, zero gap)
3. High resolution and high positioning accuracy
4. High rigidity, compact structure, high utilization rate
5. Fast speed, improve processing efficiency.

YOHOMA齿轮结构

YOHOMA gear structure



运用特殊的三齿轮消隙结构，
确保高精度运转稳定
Using a special three-gear anti-backlash
structure,
Ensure high precision and stable operation



采用NSK精密轴承
保证齿轮的高刚性和大扭力输出
Using NSK precision bearings,
Ensure the high rigidity and large torque output of the gear



较高的扭转刚度
二级还原，降低振动
最小惯量，高冲击负载能力 (5倍额定扭矩)
Higher torsional stiffness
Secondary reduction, reduce vibration
Minimum inertia, high impact load capacity
(5 times rated torque)



主轴承吸收外力和扭矩
无需额外的外部轴承
提高可靠性和降低总成本
The main bearing absorbs external
forces and torques without the need for
additional external bearings to
improve reliability and reduce overall
costs



采用世界顶尖自调式油脂
终身无需更换油脂，降低齿
轮发热性，提高转换效率
Using the world's top self-lubricating
grease, no need to replace grease for
life, reduce gear heat generation and
improve conversion efficiency

技术对比

Technology comparison

NO	传动模式	滚子凸轮	蜗轮蜗杆	DD直驱	YOHOMA 齿轮结构
1	图样				
2	接触形式	线接触	点接触	磁场接触	齿轮啮合
3	结构强度	高	低	低	高
4	电能消耗	一般	一般	高	低
5	维修成本	低	高	极高	极低
6	背隙	零背隙	必须有间隙	零背隙	零背隙
7	间隙调整量	无需	长期	无需	无需
8	刹车	轻切削时不需要	需要	需要	不需要
9	工作惯量	可调整	一般	超低	超低
10	耐久性	良好	低	一般	高
11	承重	高	一般	超低	一般
12	发热性	一般	高	高	低
13	传动效率	良好	差	良好	高

Comparison of parameters of
turntables with different structures

不同结构转台参数对比

滚子凸轮五轴转台

Roller cam five-axis turntable

滚子凸轮五轴转台采用精密凸轮与滚针轴承啮合驱动转台传动，转台精度主要依靠滚子凸轮保证。目前国外精度做的好的是日本JT五轴，国内做的比较好的是台湾TJ五轴（滚子凸轮依靠日本进口）。

滚子凸轮结构与其他减速机结构相比，有更小的减速比，跟蜗轮蜗杆结构相比，可以实现2倍以上的高速分度，滚子凸轮驱动的高刚性更高。

Roller cam five-axis turntable uses precision cams and needle bearings to engage and drive runners. The accuracy of the turntable is mainly guaranteed by roller cams. At present, the Japanese JT five-axis precision is the best one abroad, and the Taiwan TJ five-axis is the better one domestically (roller cams are imported from Japan).

Compared with other reducer structures, the roller cam structure has a smaller reduction ratio. Compared with the worm gear structure, it can achieve more than 2 times the high-speed indexing, and the roller cam drive has higher rigidity.



与滚子凸轮五轴参数对比

Comparison with five-axis parameters of roller cam

品牌	结构组成	型号	金属工件	工件公差	驱动方式	加工精度	轴系精度	传动比		最高转速		分辨率精度		重复定位精度		最大工作负载	
								滚珠轴	滚料轴	滚料轴	滚料轴	滚料轴	滚料轴	滚料轴	滚料轴	滚料轴	滚料轴
YOHOMA	凸轮结构	YHMC20	120	180/195	齿轮啮合	0.06	±115"	1:51	1:81	48	48	18"	15"	3"	3"	35	35
日本T	滚子凸轮	TR2-130	135	250	气压	0.08	<30° ~ +110°	1:48	1:80	62	52	20"	30"	4"	8"	35	30
YOHOMA	凸轮结构	YHMC60	160	180/215	齿轮啮合	0.012	±120°	1:81	1:121	48/37	50/25	18"	25"	3"	5"	45	35
日本T	滚子凸轮	TRU-160	160	300	气压	0.19	-30° ~ +107°	1:60	1:60	80	52	20"	30"	4"	8"	65	40
台湾T	滚子凸轮	PAR160	160	255	气压		±100°	1:60	1:60	82	282	20"	30"	4"	8"	35	30
YOHOMA	凸轮结构	YHMC120	200	231	齿轮啮合	0.17	±120°	1:121	1:121	60/25	40/25	21"	21"	5"	8"	82	40
日本T	滚子凸轮	TRN-200	200	300	油压	0.59	-30° ~ +110°	1:45	1:90	44	32	30"	45"	4"	8"	120	40
YOHOMA	凸轮结构	YHMC50	250	295	齿轮啮合	0.78	±120°	1:121	1:121	60/25	40/25	22"	22"	5"	8"	100	65
台湾T	滚子凸轮	PAR255	255	300	油压		±110°	1:120	1:120	35	16.6	15"	30"	4"	8"	100	75

蜗轮蜗杆五轴转台

Worm gear five-axis turntable

市场上很多的高精密数控五轴转台都是采用蜗轮蜗杆结构。品质做的比较好的是日本JT五轴转台和日本N字头五轴转台，其次是台湾TJ五轴转台。五轴转台采用蜗轮蜗杆结构传动，其关键是硬质合金蜗杆和蜗轮采用特殊钢通过特殊的热处理，蜗轮是进过渗氮处理硬度达到HV930，再对蜗轮表面进行等离子渗氮处理，很好的解决了滑动磨损的难题，大大保证了加工精度，但大大提高生产成本。

Many high-precision CNC five-axis turntables on the market adopt a turbo-worm structure. The better quality is the Japanese JT five-axis turntable and the Japanese N-head five-axis turntable, followed by the Taiwan TJ five-axis turntable. The five-axis turntable is driven by a worm gear structure. The key is that the carbide worm and worm wheel are made of special steel through special heat treatment. The worm wheel is nitrided and the hardness reaches HV930. Then plasma nitriding is performed on the surface of the worm wheel. The problem of sliding wear is solved, the machining accuracy is greatly ensured, but the production cost is greatly increased.



照片是5AX-130FA



与涡轮蜗杆五轴转台对比

Compared with five-axis turntable with worm gear

品牌	结构组成	型号	金属工件	工件公差	驱动方式	加工精度	轴系精度	传动比		最高转速		分辨率精度		重复定位精度		最大工作负载	
								滚珠轴	滚料轴	滚料轴	滚料轴	滚料轴	滚料轴	滚料轴	滚料轴	滚料轴	滚料轴
YOHOMA	凸轮结构	YHMC20	120	180/195	齿轮啮合	0.06	±115"	1:51	1:81	48	48	18"	15"	3"	3"	35	35
日本T	蜗轮蜗杆	TWA-150	150	230	气压	0.08	-30° ~ +110°	1:60	1:120	80	25	40"	45"	4"	8"	35	30
日本T	蜗轮蜗杆	SAS-130	130	225	空压	0.12	0° ~ +110°	1:90	1:81	32	16	30"	60"			50	25
台湾T	蜗轮蜗杆	FAB125	125	215	气压		-30° ~ +120°	1:50	1:50	44.4	44.4	40"	30"	4"	6"	50	35
YOHOMA	凸轮结构	YHMC60	160	180/215	齿轮啮合	0.012	±120°	1:81	1:121	48/37	50/25	18"	21"	3"	5"	45	35
日本T	蜗轮蜗杆	TWA-160	160	300	空压	0.19	-30° ~ +110°	1:60	1:120	80	25	30"	45"	4"	8"	60	40
台湾T	蜗轮蜗杆	FAB170	170	245	气压		±100°	1:72	0.125	32.2	25	30"	30"	4"	8"	60	40
YOHOMA	凸轮结构	YHMC120	200	231	齿轮啮合	0.17	±120°	1:121	1:121	60/25	40/25	21"	21"	5"	8"	82	40
日本T	蜗轮蜗杆	TWA-200	200	300	油压	0.59	-30° ~ +110°	1:45	1:90	44	32	30"	45"	4"	8"	120	40
日本T	蜗轮蜗杆	SAS-201	200	280	油压	0.12	0° ~ +105°	1:90	1:180	32	16	30"	60"			80	50
台湾T	蜗轮蜗杆	FAB210	210	270	油压		±100°	1:90	1:90	32.2	32.2	30"	30"	4"	8"	75	50
YOHOMA	凸轮结构	YHMC150	250	295	齿轮啮合	0.78	±120°	1:121	1:121	60/25	40/25	22"	22"	5"	8"	100	65
日本T	蜗轮蜗杆	SAS-250	250	285	油压	0.5	-30° ~ +120°	1:90	1:180			20"	60"			80	50
台湾T	蜗轮蜗杆	FAB255	255	290	油压		±110°	1:120	1:120	25	16.6	15"	30"	4"	8"	100	75

YOHOMA与知名涡轮蜗杆五轴转台参数对比优势:

Comparative advantages of YOHOMA and well-known five-axis turntable parameters:

- | | |
|------------------------------------|--|
| 1.转速相对更快，加工效率更高。 | 1: The speed is relatively faster and the processing efficiency is higher. |
| 2.分割精度相比更高，加工精度更高。 | 2: The segmentation accuracy is higher, and the processing accuracy is higher. |
| 3.不需要气压或者油压，完全依靠齿轮啮合自锁，联动加工效果相对更好。 | 3: No air pressure or oil brake is required, and the gear meshing and self-locking are completely dependent, and the linkage processing effect is relatively better. |

台湾DD直驱五轴转台

Taiwan DD direct drive five-axis turntable

DD直驱五轴转台是电机直接驱动负载，无减速机，无背隙，低噪音，结构紧凑，因为DD马达的价格成本非常高和不能大负载，使其发展缓慢很多著名的公司都没有研发相关联的产品。目前在市场上做的比较好也只有台湾TJ五轴研发的DD马达五轴转台。

DD直驱五轴在立柱型立加机或者钻攻机搭配可兼容式，立式车床使用，旋转轴超高速2000rpm，DD马达无间隙精密可以长期保持良好。

The DD direct drive five-axis turntable is a motor that directly drives the load, no reducer, no backlash, low noise, and compact structure. Because the price of DD motor is very high and the load cannot be large, its development is slow. Many well-known companies have not developed related products. At present, there is only a five-axis turntable with DD motor developed by Taiwan TJ five-axis.

DD direct-drive five-axis vertical machining machine or drilling and tapping machine can be used with horizontal and vertical lathes. Therotating shaft has an ultra-high speed of 2000rpm. The DD motor has no gap and precision can be maintained for a long time.



DD马达直驱
DD motor direct drive

与台湾DD直驱五轴转台性能对比

Comparison with Taiwan DD direct drive five-axis turntable performance

品牌	结构组成	型号	台面直径	工作台面高度	最小定位精度		倾斜角度	减速比		最高转速		分度精度		重复定位精度		最大工作负载	
					旋转轴	倾斜轴		旋转轴	倾斜轴	旋转轴	倾斜轴	旋转轴	倾斜轴	旋转轴	倾斜轴	水平时	倾斜时
YOHOMA	齿轮结构	YHM120	180	180/215	0.001	0.001	±120°	1:81	1:121	48/37	50/25	16"	20"	3"	3"	46	35
台湾品牌	DD直驱	FAD170	170	250	0.001	0.001	±100°	直接	直接	250/300	150/200	20"	30"	4"	6"	50	30
YOHOMA	齿轮结构	YHM350	350	2430	0.001	0.001	±120°	1:161	1:161	15	15	23"	20"	8"	8"	300	190
台湾品牌	DD直驱	FAD-300	300	385	0.001	0.001	±120°	直接	直接	800	50	20"	30"	4"	4"	100	100

YOHOMA advantage YOHOMA优势

YOHOMA市场优势 YOHOMA market advantage



- 1: 倾斜角度同行业最大±120°可客观化加大加工角度，提高加工效率。
- 2: YHM120在同行业高度最低：180mm，可适用更多的雕刻机和钻攻机。
- 3: 采用YOHOMA齿轮结构传动，相比其他品牌转台分度精度和重复定位精度更高，高精密加工。
- 4: YOHOMA五轴转台在不停加工状态下，发热性非常低，耐久性强，传动效率高，使用寿命长维修率极低。
- 5: 采用YOHOMA齿轮结构传动，高刚性和大扭力输出。
- 6: 滚轮蜗杆和滚子凸轮传统结构，只能通过提高金属材料保证精度但成本极高，YOHOMA五轴在价格上非常有市场优势。

- 1: The tilt angle is the largest in the industry: ±120° can be objectively increased processing angle, improve processing efficiency.
- 2: YHM120 has the lowest height in the same industry: 180mm, suitable for more engraving and milling machines and drilling and tapping machines.
- 3: It adopts YOHOMA gear structure transmission, which has higher division accuracy and repeat positioning accuracy than other brands of turntables, and high-precision processing.
- 4: The YOHOMA five-axis turntable has very low heat generation, high durability, high transmission efficiency, long service life, and low maintenance rate under non-stop processing.
- 5: Using YOHOMA gear structure transmission, high rigidity and large torque output.
- 6: Compared with the traditional structure of worm gears and roller cams, the accuracy can only be ensured by improving the metal material, but the cost is extremely high. YOHOMA five-axis has a market advantage in price.

刹车不良的转台：会震刀

- ①加工圆棒型工件时，会产生震刀现象
- ②使用过桥板（中板）加工时，过桥板会颤抖并严重损伤蜗轮，导致精度不准

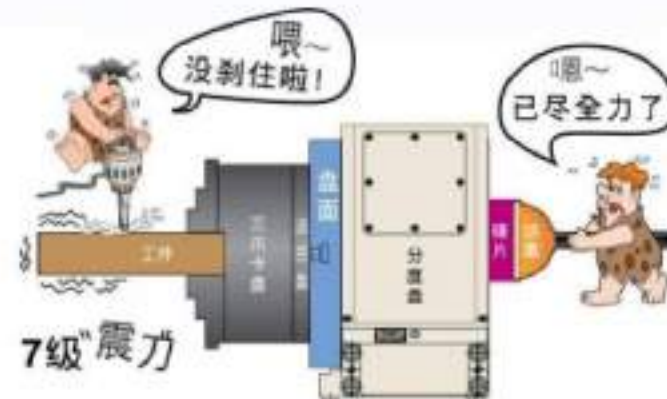

7级震刀

YOHOMA齿轮结构齿轮啮合自锁 拒绝气压、液压装置

YOHOMA gear structure gear Engagement and self-locking Rejects pneumatic and hydraulic devices



增压缸



液压站

市场上绝大部分都是采用气压和液压自锁。油刹自锁还需要配液压站。不管气刹还是液刹给信号都需要反应时间。而YOHOMA五轴转台采用齿轮啮合自锁，能快速联动，提高加工效率。然而长时间使用气压液压容易漏压，影响刹车效果，降低加工精度。

Most of the market adopts pneumatic and hydraulic self-locking. The oil brake self-locking also needs a hydraulic station. Regardless of whether the air brake or the liquid brake gives a signal, it needs response time. The YOHOMA five-axis turntable adopts gear meshing and self-locking, which can quickly link and improve processing efficiency. However, long-term use of pneumatic and hydraulic pressure is easy to leak pressure, which affects the braking effect and reduces processing accuracy.